

**Problem : 15.12** A pentagonal pyramid of height 45 mm and base edge 30 mm is resting on its base with one base edge parallel 10 mm behind and nearer to PP. The station point is 22mm in front of PP, 38 mm to the left of the axis and 55 mm above GP. Draw the perspective view.

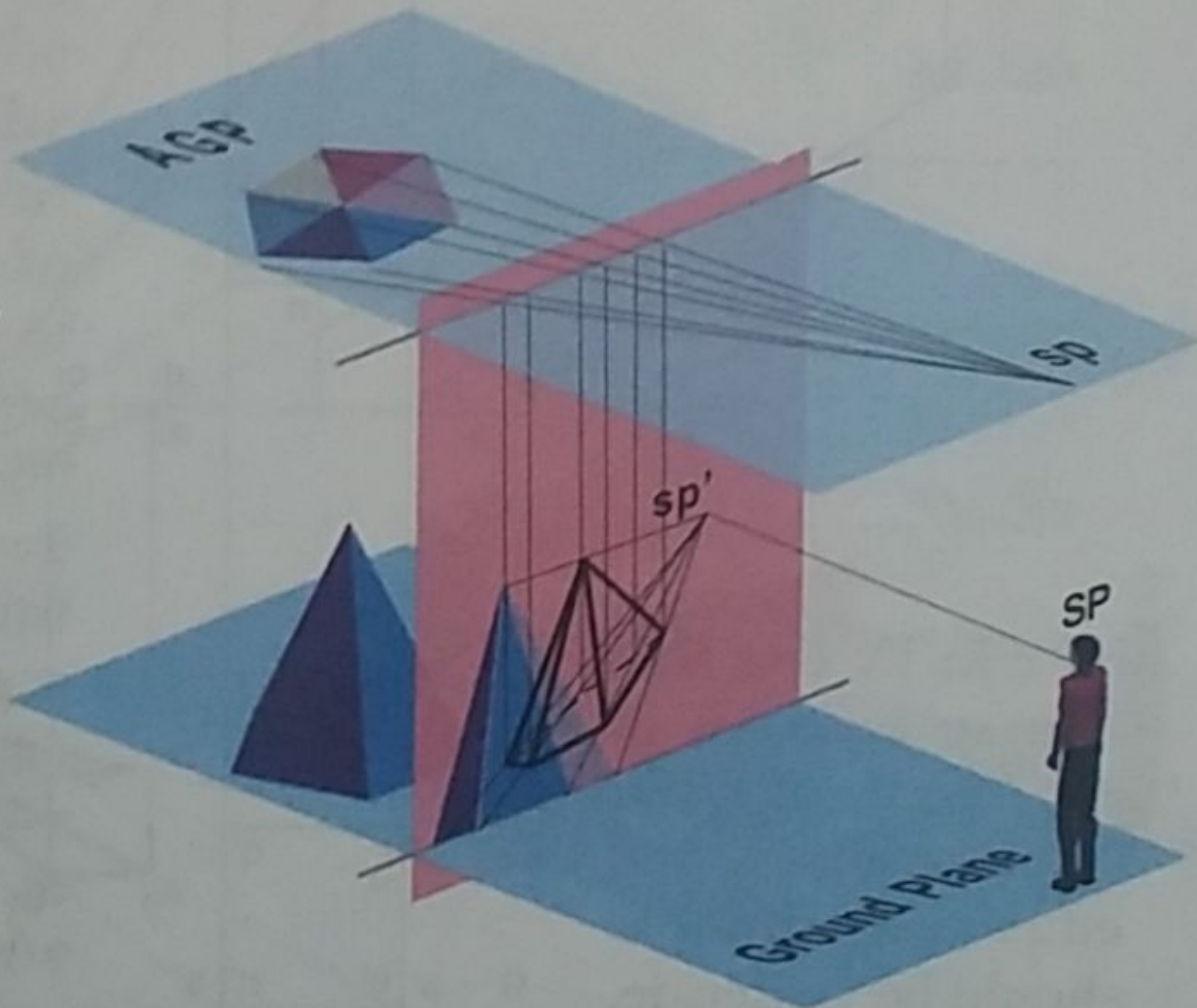

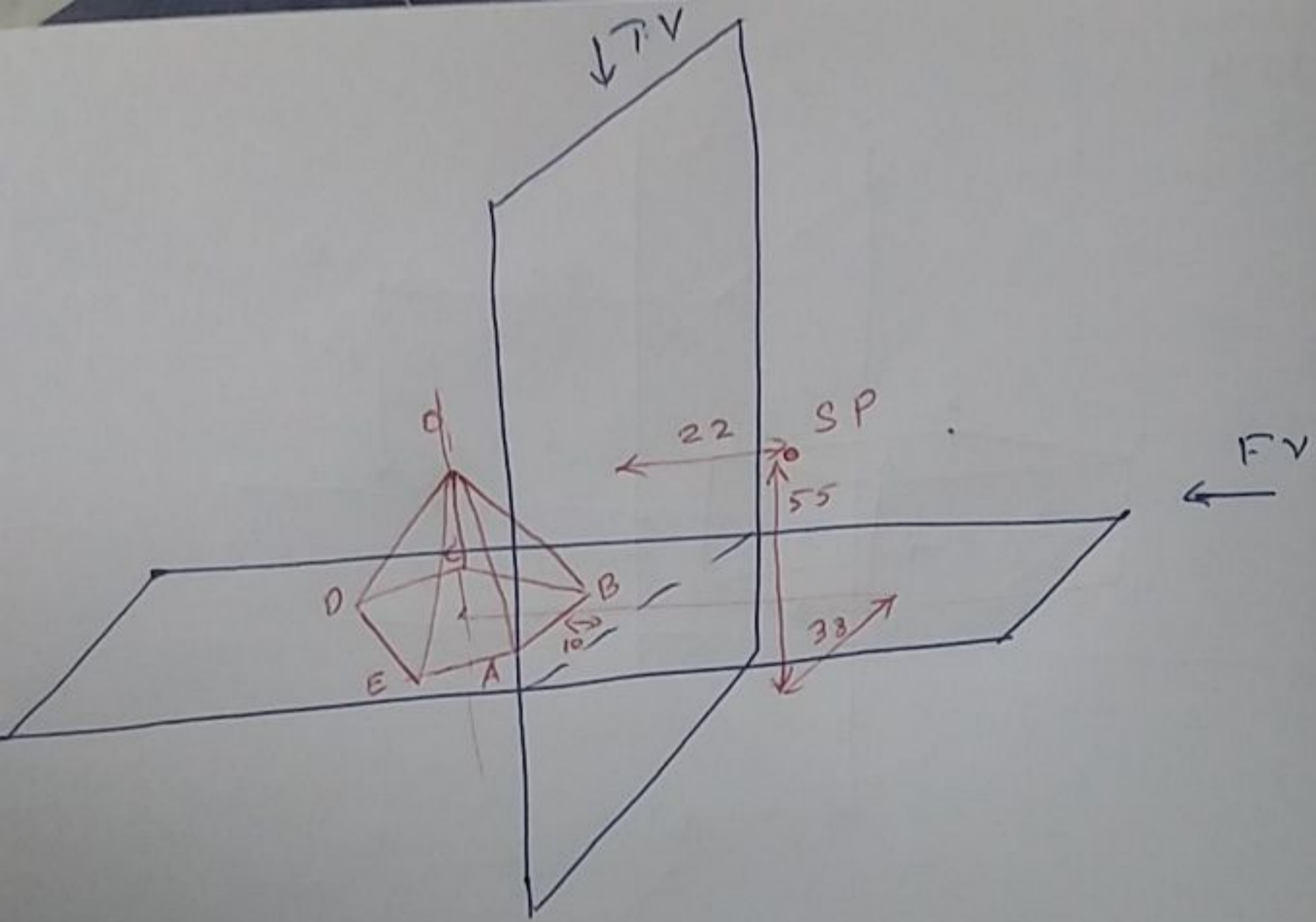

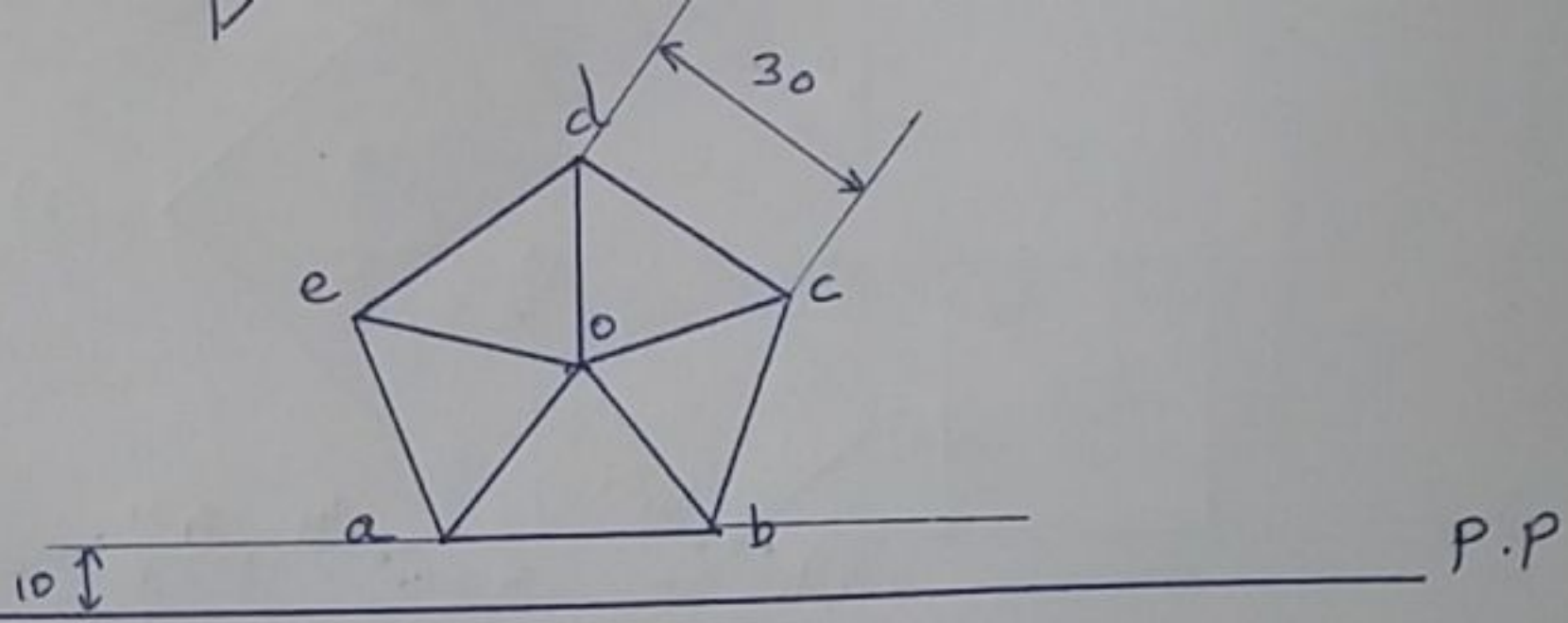

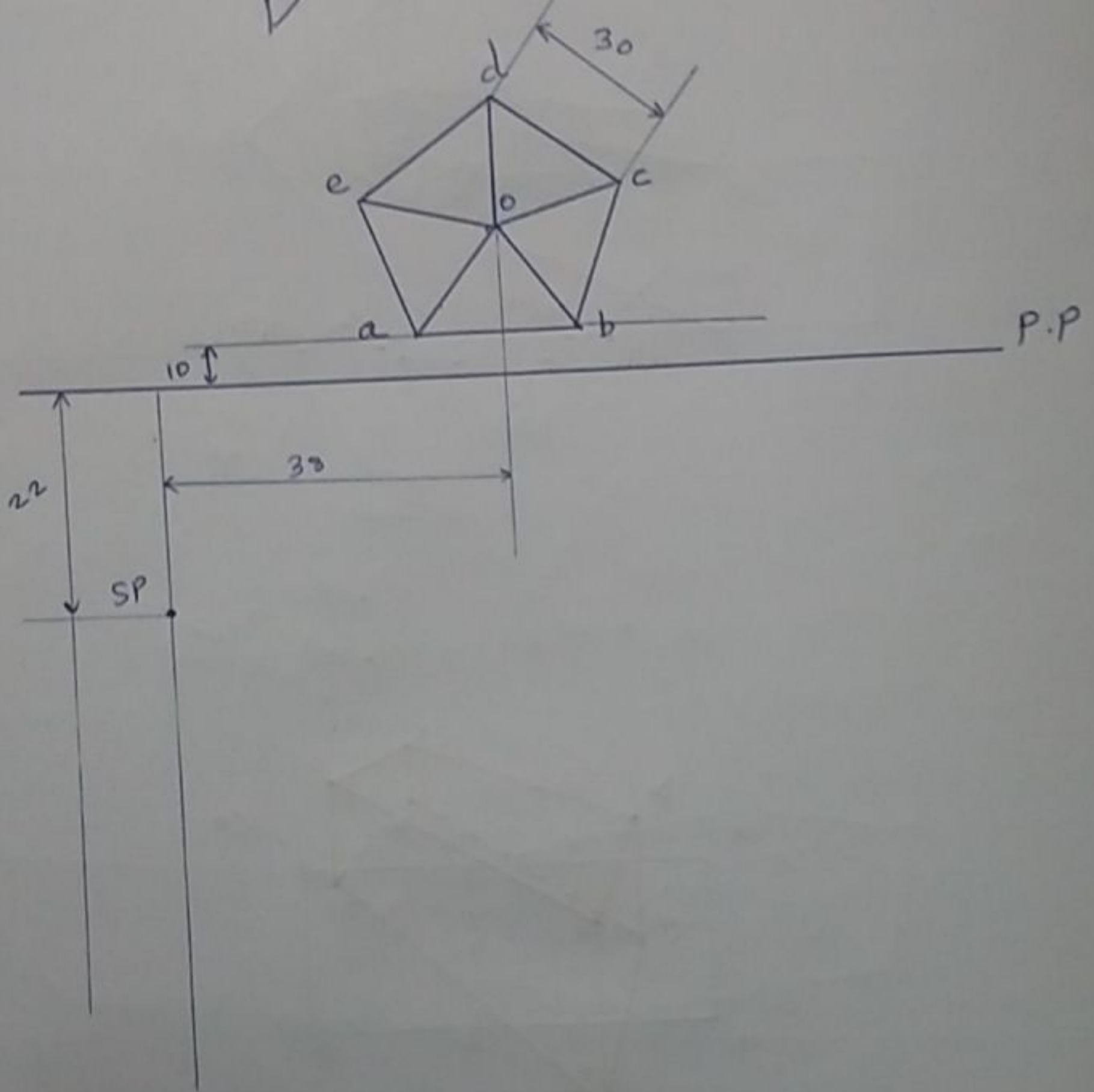

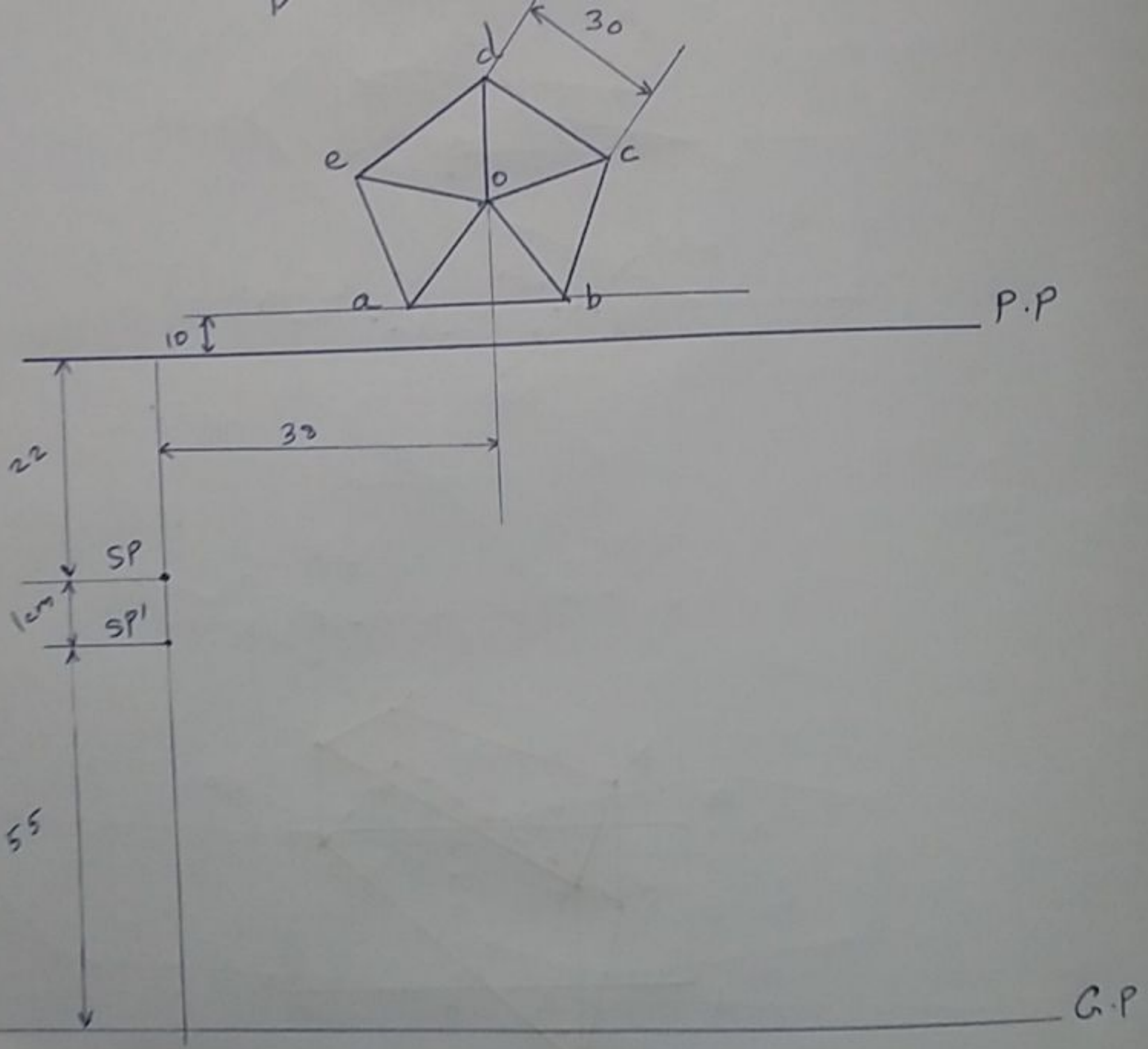

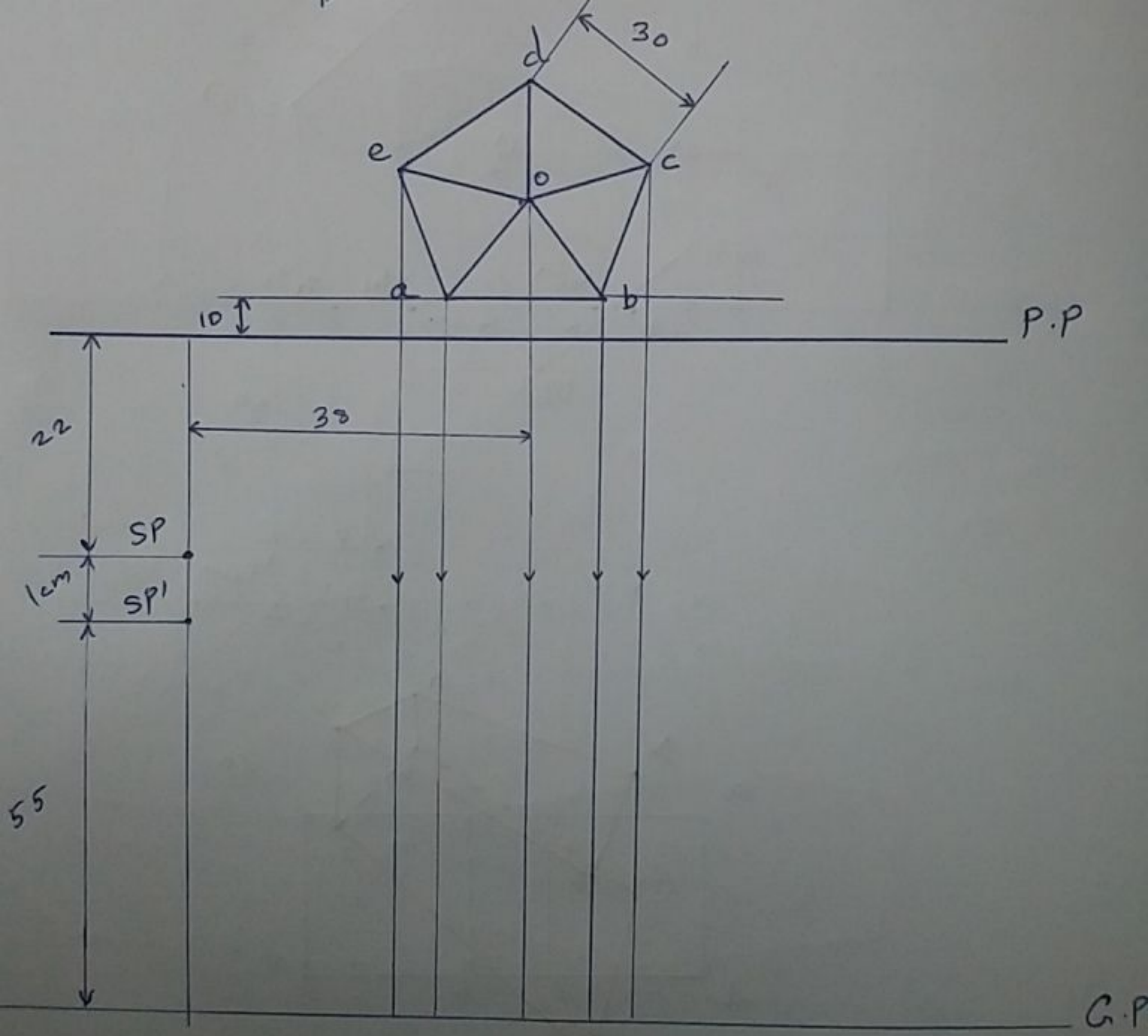

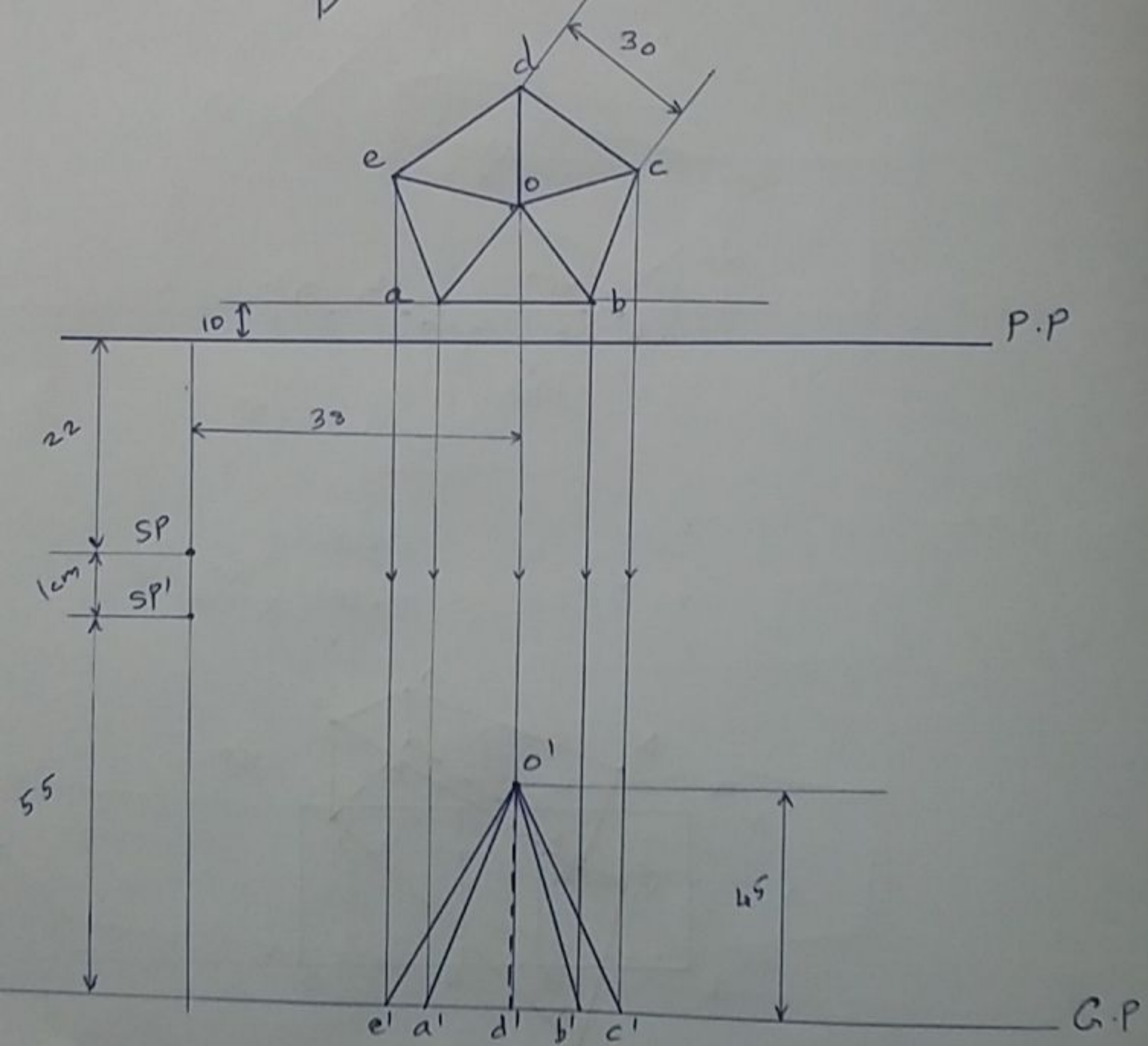

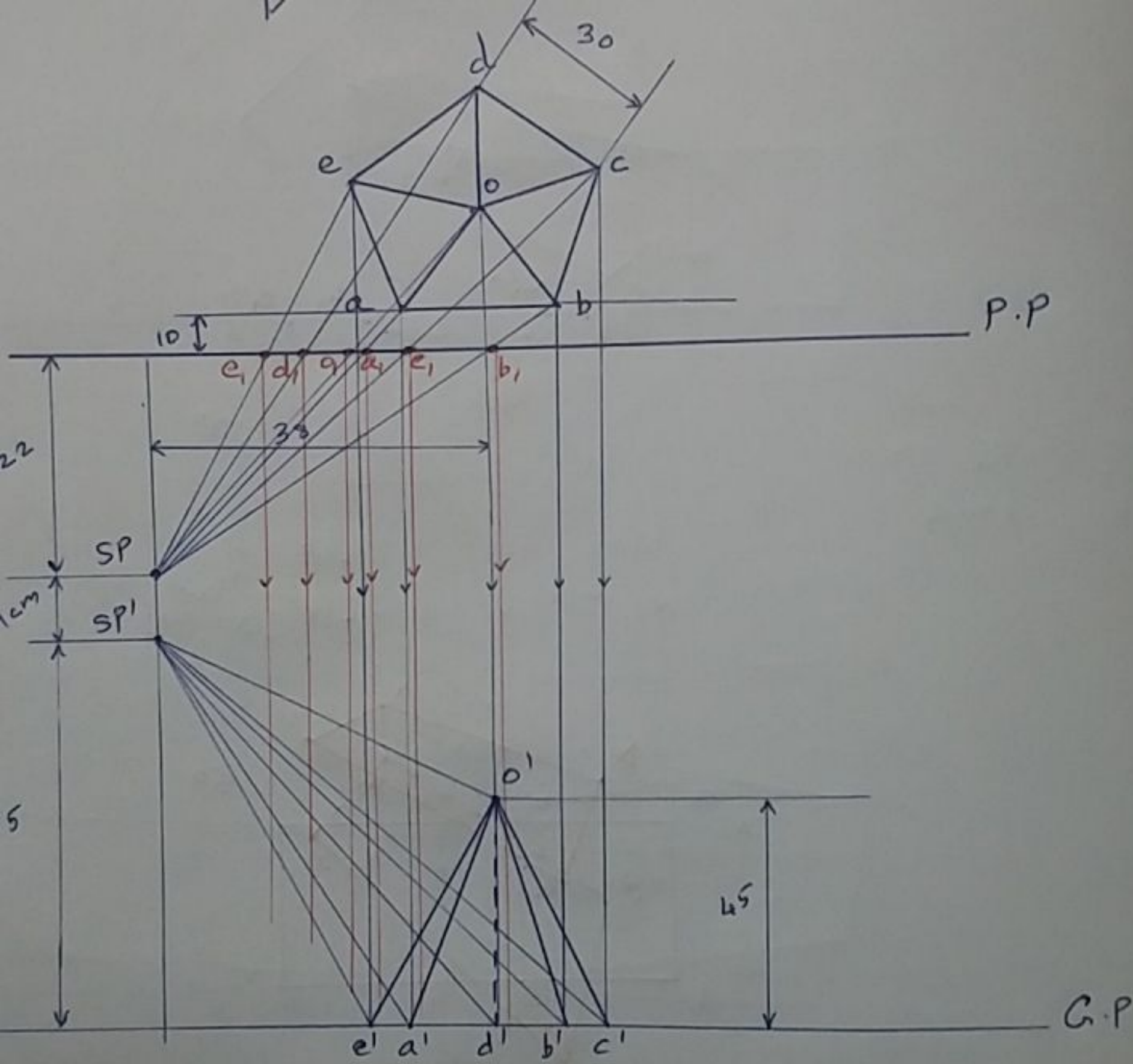



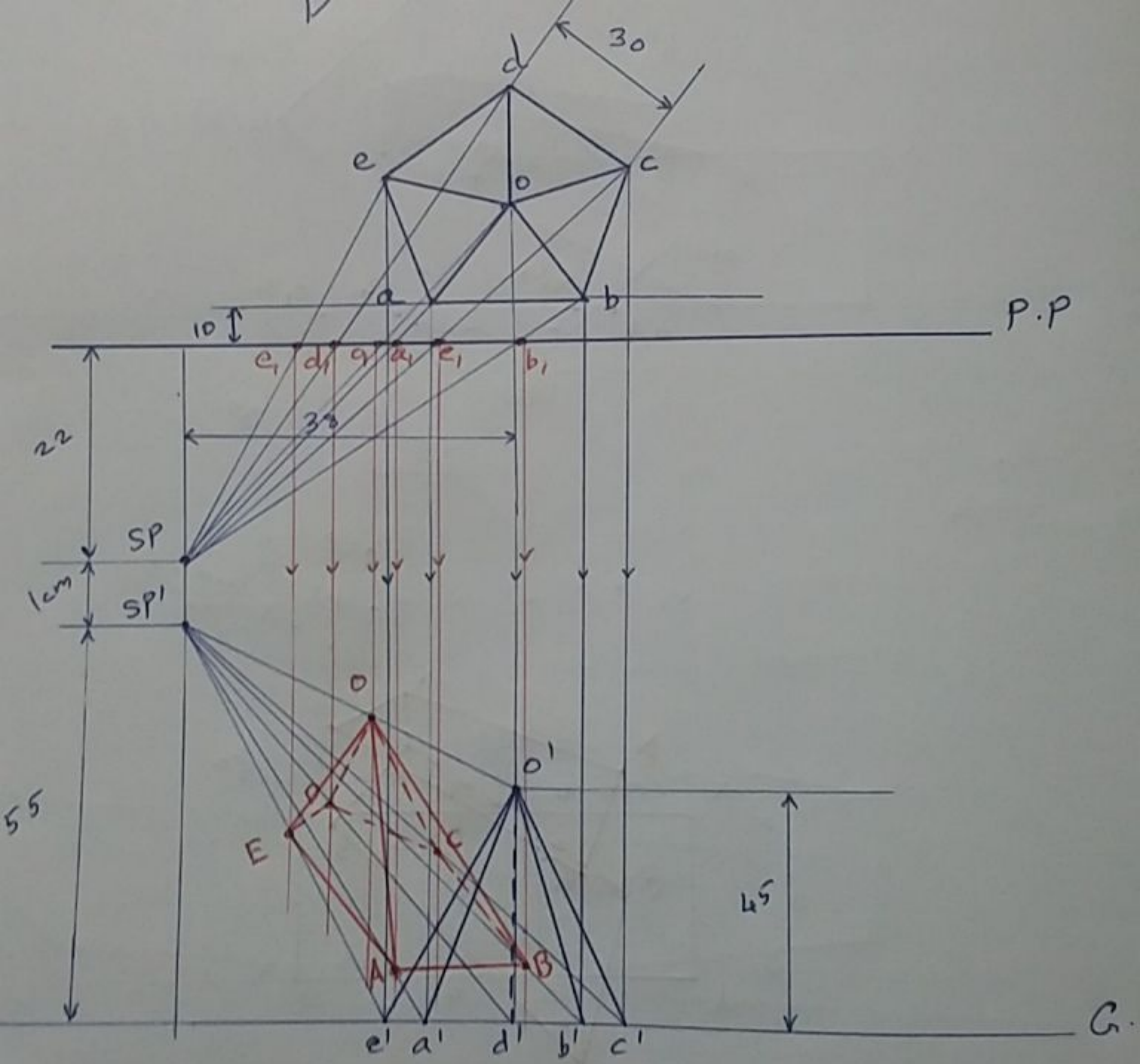

A square prism ht. 40mm & base 25mm is resting on its base on ground with one face touching P.P. S.P is 40mm to the right of axis of solid, 35mm in front & ~~35mm~~ 50mm above C.P. Assume the entire solid is in front of P.P draw its perspective projection.

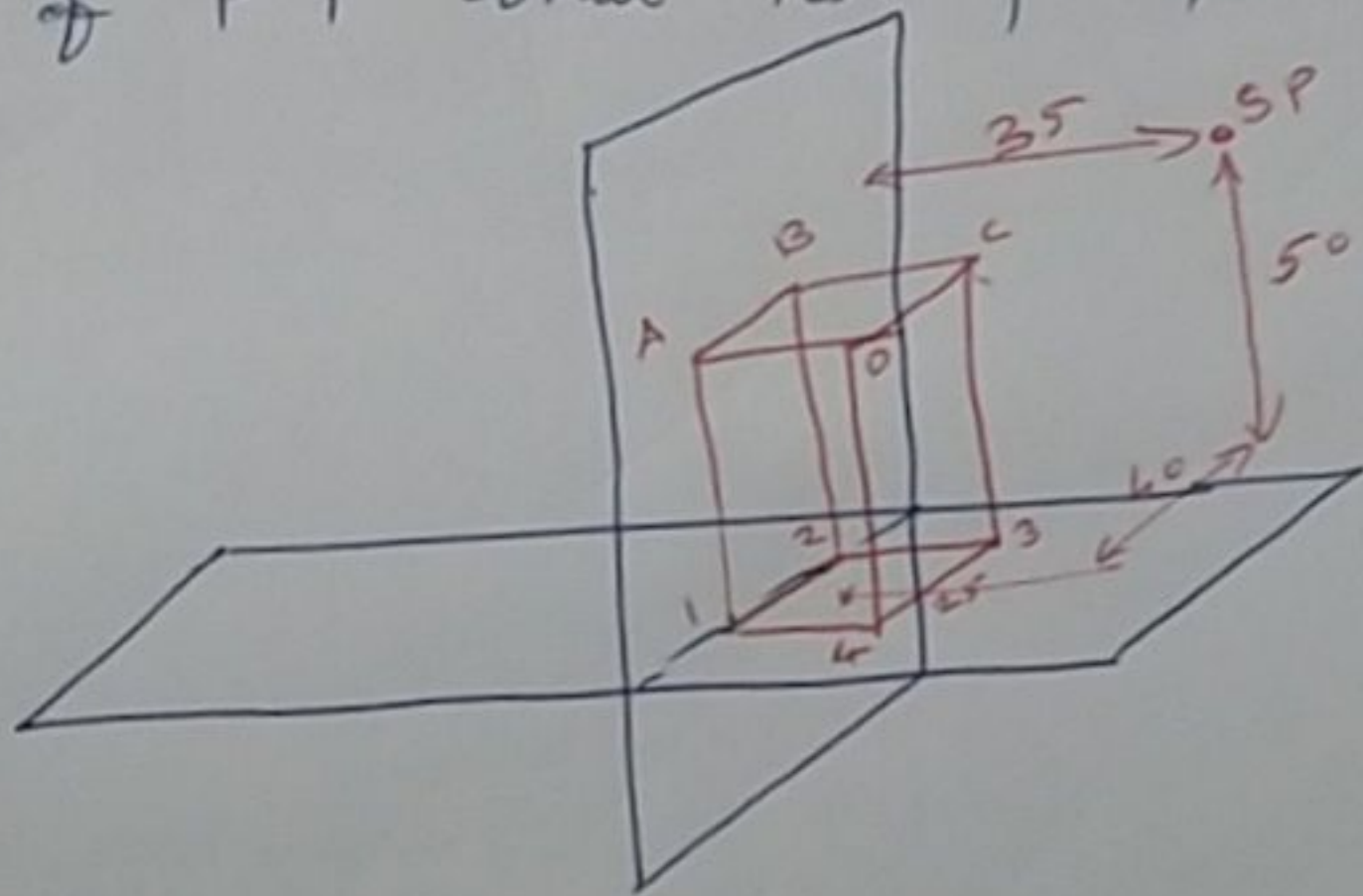

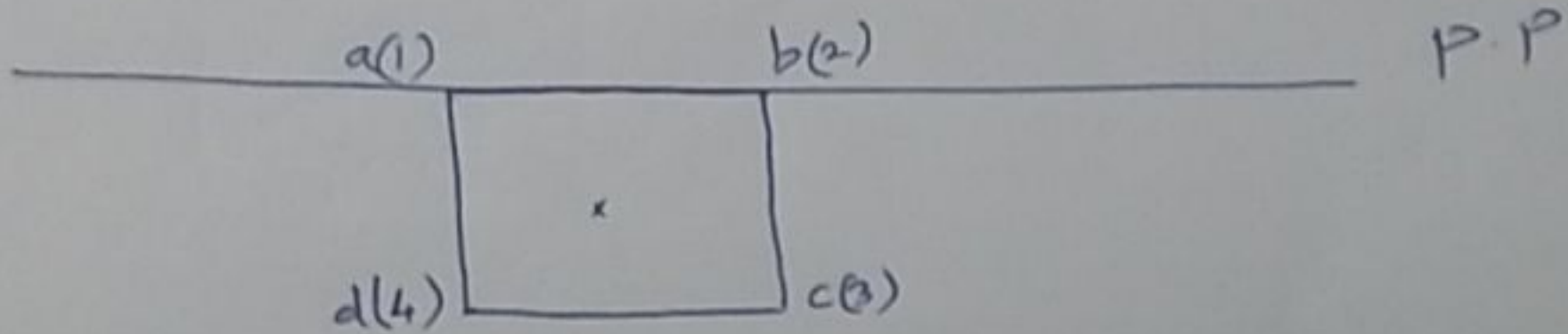

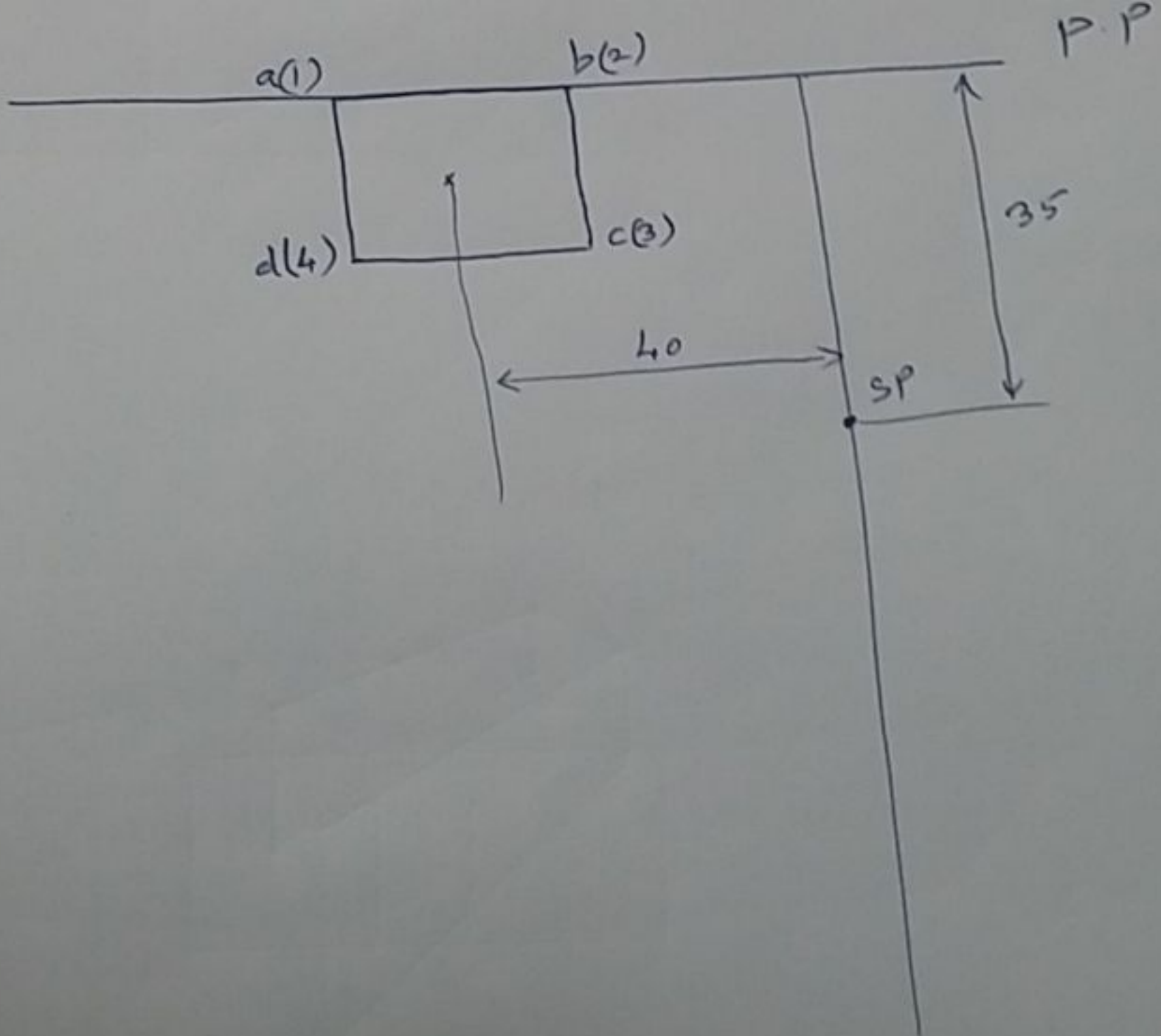

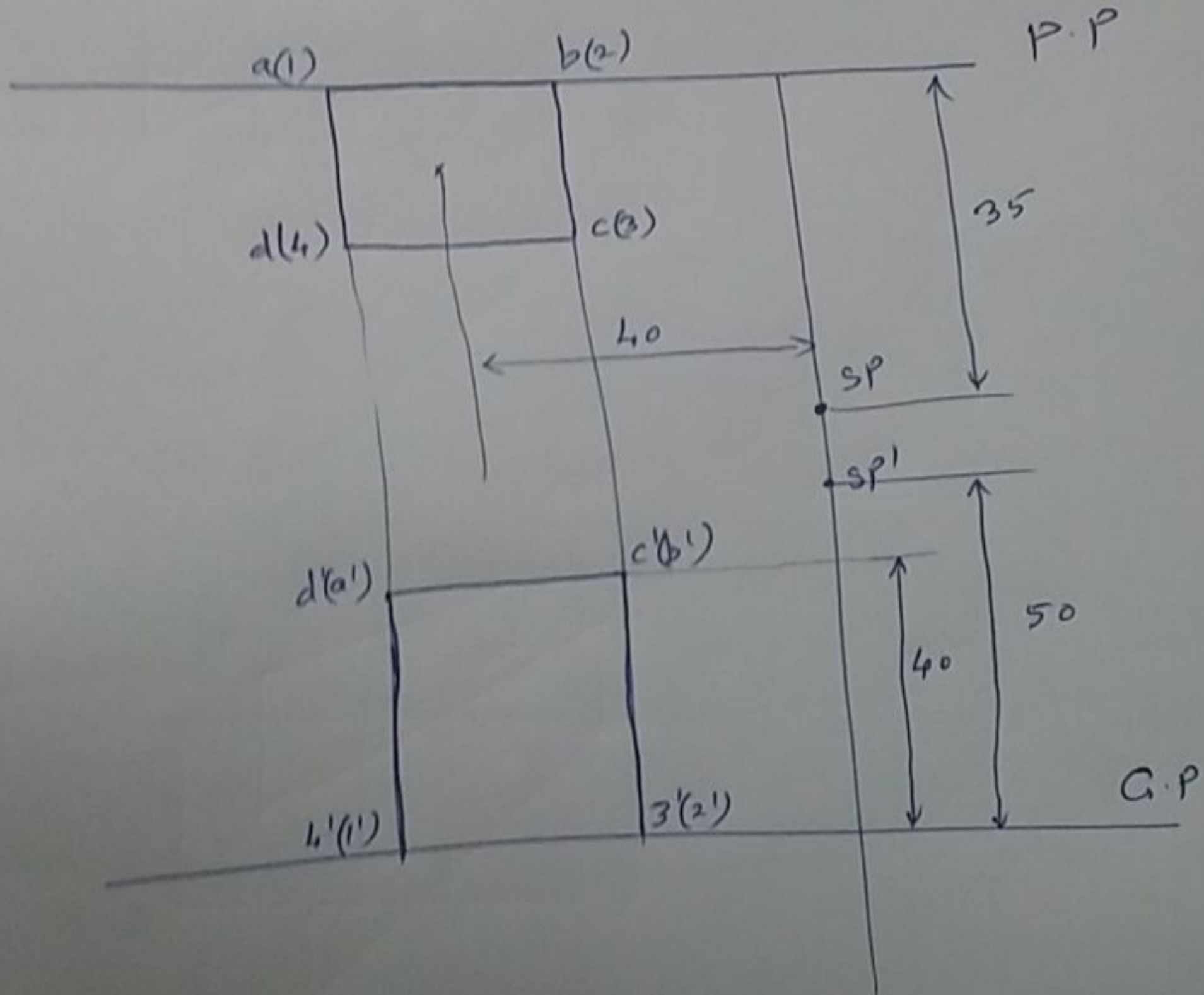

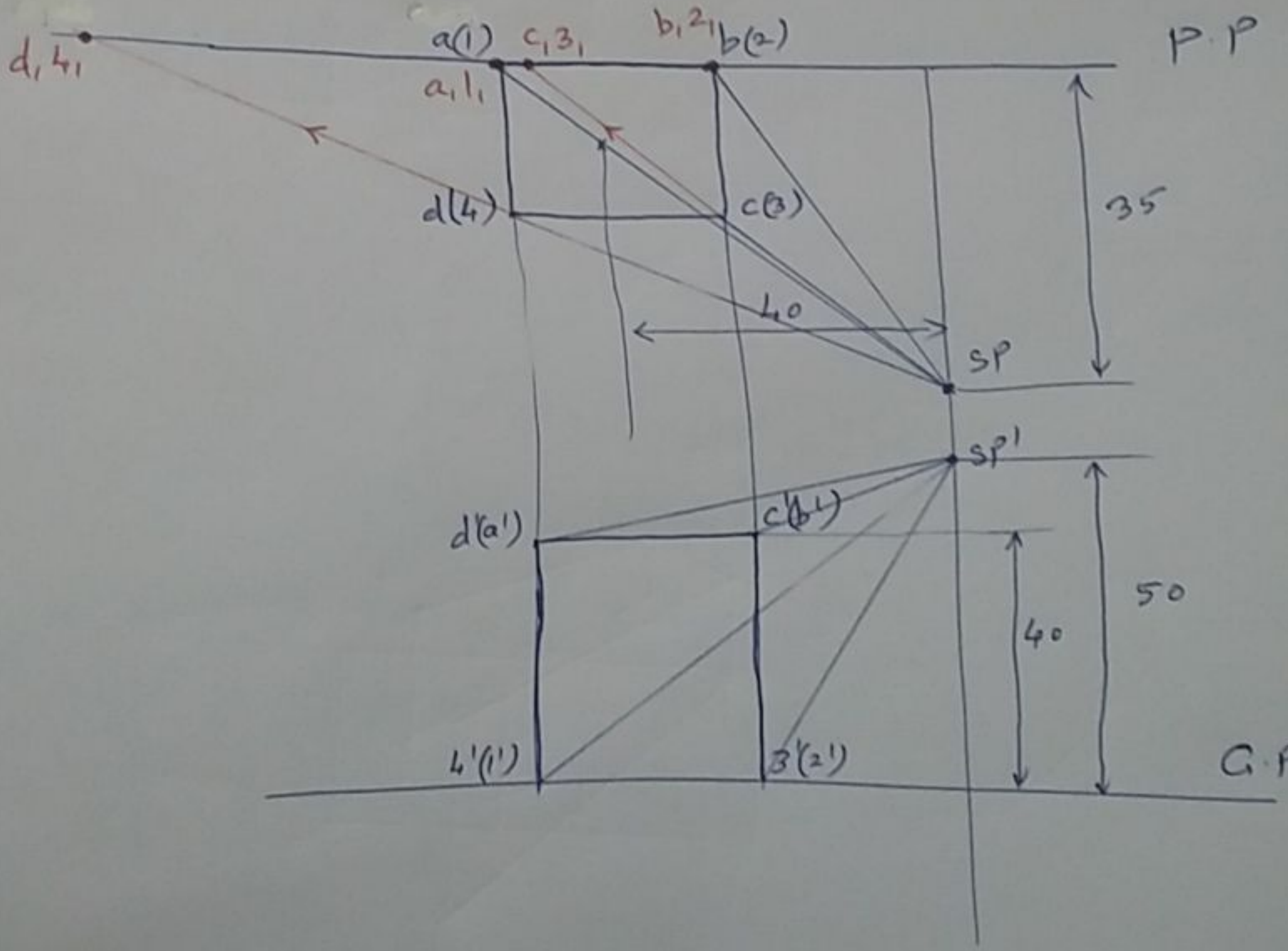

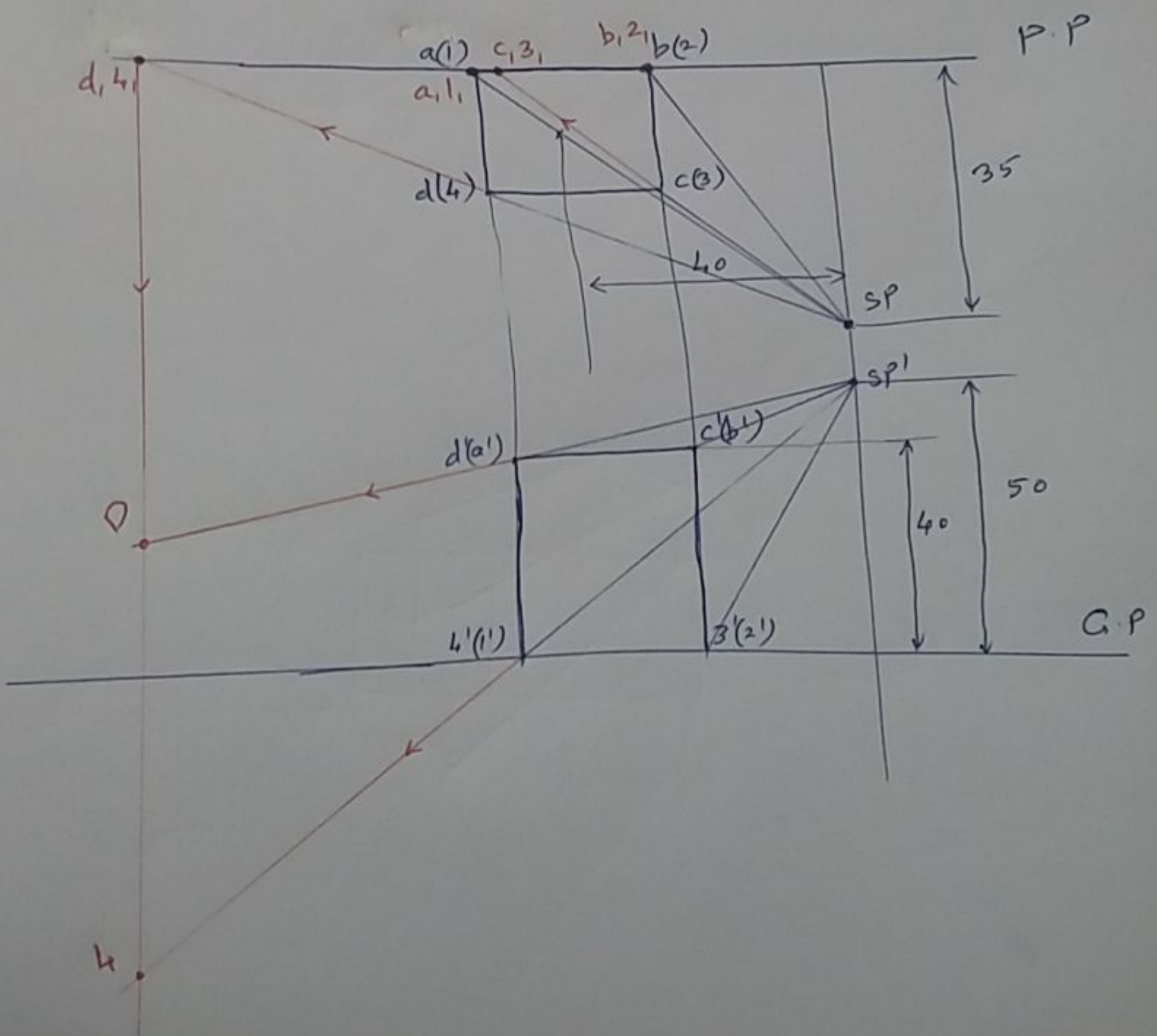

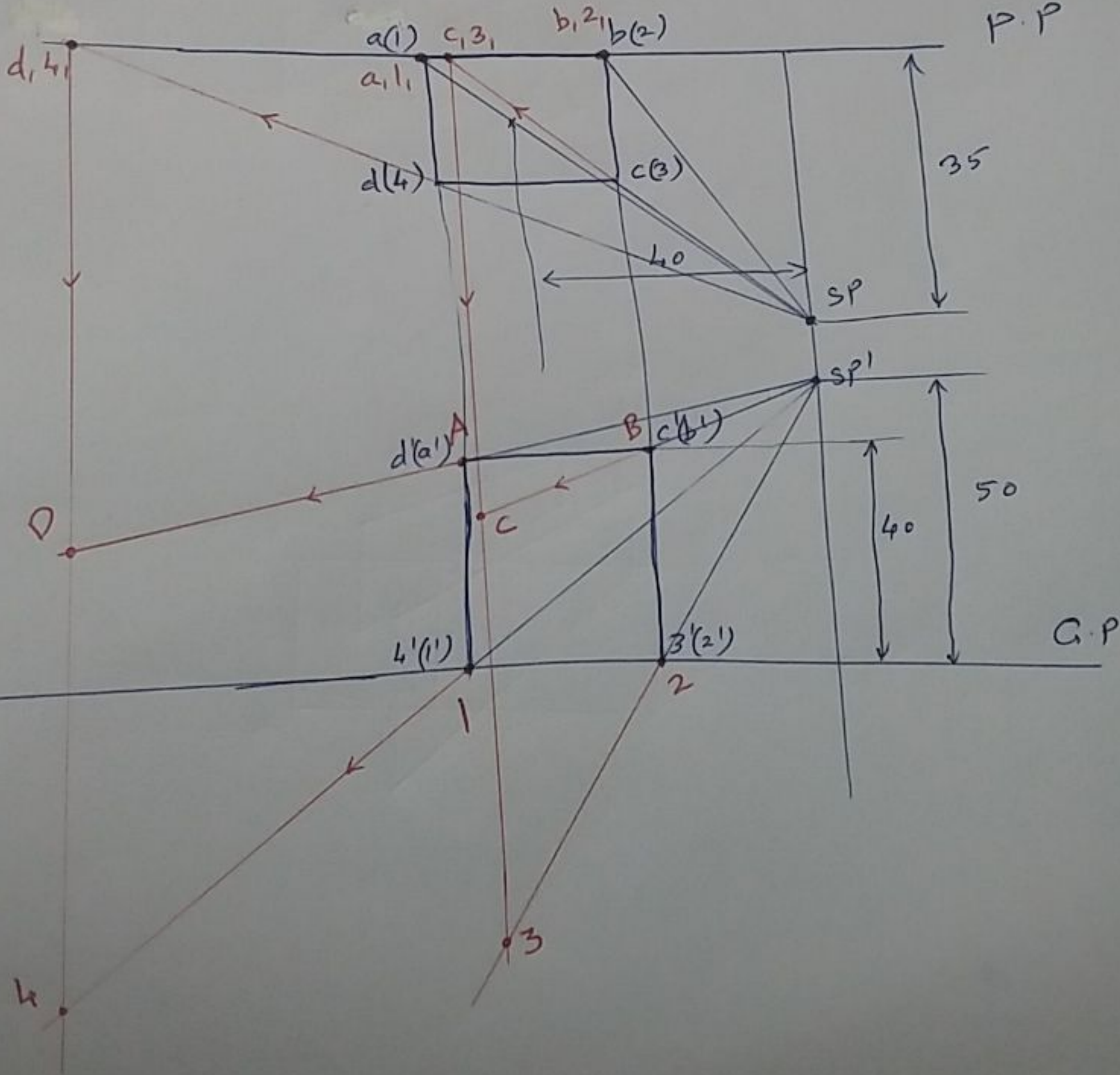



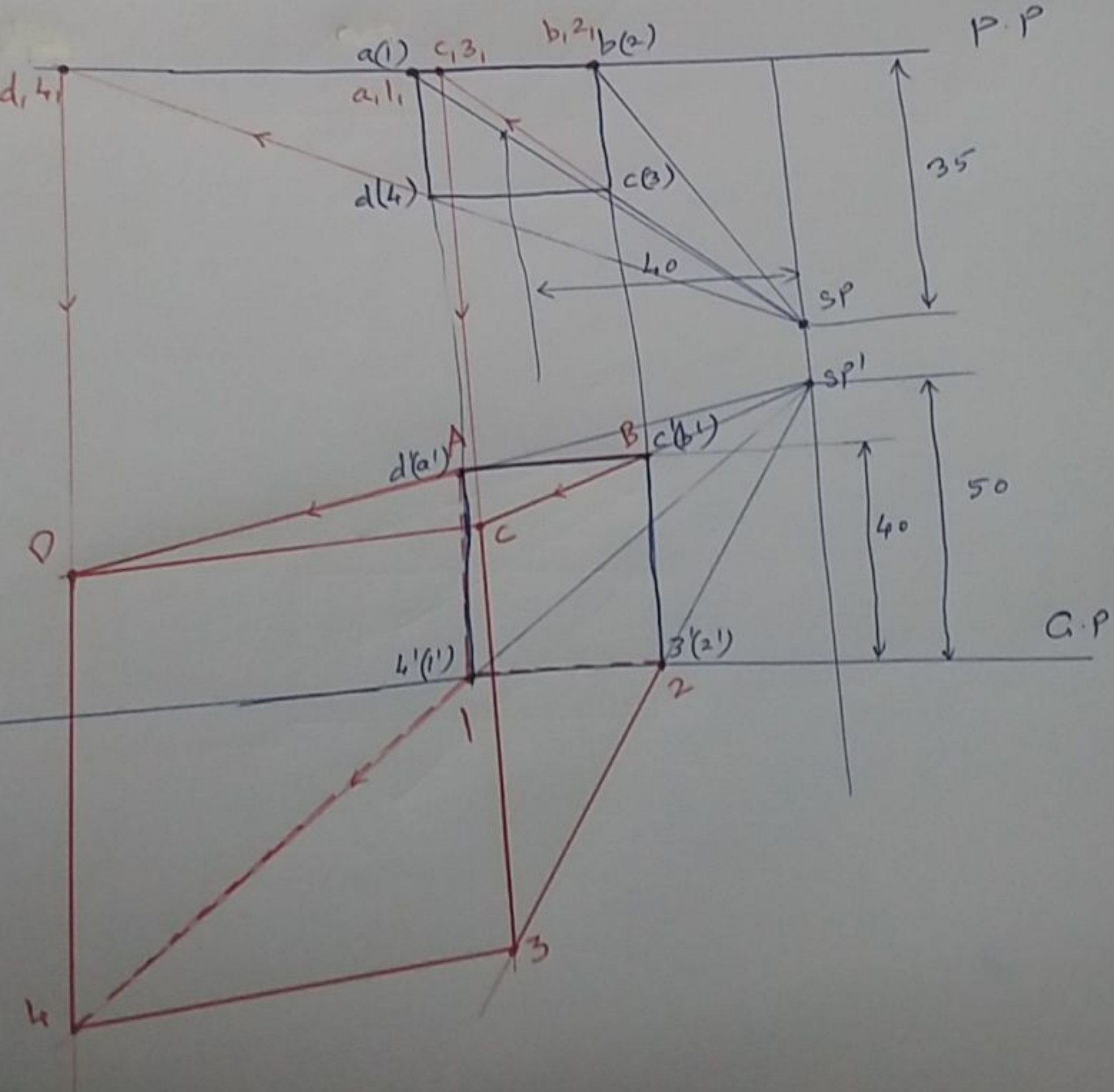

Problem : 15.15 A cone, base circle diameter 50 mm and height 60 mm is resting on its base with its axis 40 mm behind the PP. The station point is 30 mm in front of the PP, the central plane 35 mm to the left of the axis and the horizon line, 40 mm above GL. Draw the perspective view.

Problem : 15.15 A cone, base circle diameter 50 mm and height 60 mm is resting on its base with its axis 40 mm behind the PP. The station point is 30 mm in front of the PP, the central plane 35 mm to the left of the axis and the horizon line, 40 mm above GL. Draw the perspective view.

